

# CSOFR-P

## 超硬鋼用フラッシュリーマ(オイルホール付) Solid Carbide Flash Reamer for Steel with Oil Hole

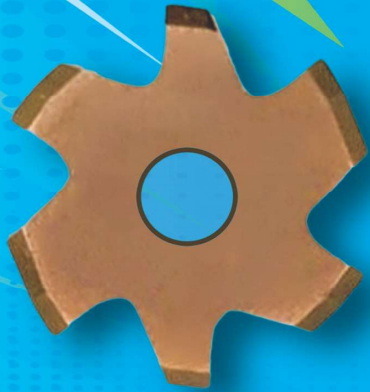

150～300m/minの切削速度で加工が可能な高速加工用リーマ

Reamer for high speed machining capable of 150～300m/min cutting speed.

センタースルーのオイルホール採用により、止まり穴の加工で十分なクーラントが可能

Adopting Center-through Oil hole, it is possible to have sufficient coolant flow in blind hole.

不等分割の採用により、高速加工でも高い精度を保証

The adoption of uneven partitioning ensures high precision even in high-speed processing.

### 切削条件参考表 Cutting Condition Table

直径 (DC) Dia.	切削速度 Cutting Speed 150～300m/min		リーマ取り代 (mm/直径) Removal Amount (mm/Dia.)
	回転数 Spindle Speed rpm	送り Feed 0.6 ~ 2.0(mm/rev) mm/min	
6	7,958 ~ 15,915	4,775 ~ 19,099	0.1
8	5,968 ~ 11,937	4,775 ~ 19,098	0.1
10	4,775 ~ 9,549	4,775 ~ 17,188	0.15
12	3,979 ~ 7,958	4,775 ~ 15,913	0.2

**EIKO** 株式会社 栄工舎  
EIKOSHA CO., LTD.  
<http://www.eiko-sha.co.jp/>

EIKO TOOL



# CSOFR-P

## 超硬鋼用フラッシュリーマ (オイルホール付) Solid Carbide Flash Reamer for Steel with Oil Hole

**K10** **P Coating** **食付 60°** **右ネジレ 5°**

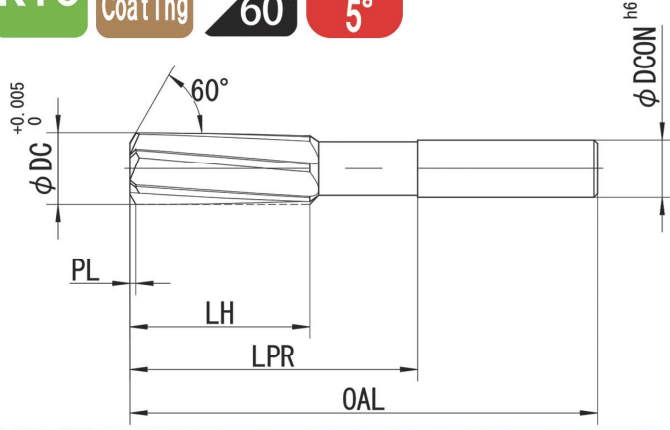

右刃右ネジレ5° Pコーティング 食付角度60°  
Helix-Angle Right 5° P-Coated Chamfer Angle 60°

### フラッシュリーマ(高速加工用) Flash Reamer for High Speed Machining

公差 Tolerance	DC	DCON
	+0.005 0	h6

外径 DC Dia.	食付長 (PL) Chamfer Length	刃長 (LH) Length of Flutes	首下長 (LPR) Protruding Length	全長 (OAL) Overall Length	シャンク径 (DCON) Shank Dia.	刃数 (N) Number of Flutes
5.97 ~ 5.99	0.4	25	40	65	5	6
6.0	0.4	25	40	65	5	6
6.01 ~ 6.05	0.4	25	40	65	5	6
6.1 ~ 6.5	0.5	25	40	65	6	6
6.6 ~ 6.9	0.5	25	40	65	6	6
6.97 ~ 6.99	0.5	25	40	65	6	6
7.0	0.5	25	40	65	6	6
7.01 ~ 7.05	0.5	25	40	65	6	6
7.1 ~ 7.5	0.5	25	40	65	6	6
7.6 ~ 7.9	0.5	25	40	65	6	6
7.97 ~ 7.99	0.5	25	40	65	6	6
8.0	0.5	25	40	65	6	6
8.01 ~ 8.05	0.5	25	40	65	6	6
8.1 ~ 8.5	0.6	25	40	65	8	6
8.6 ~ 8.9	0.6	25	40	65	8	6
8.97 ~ 8.99	0.6	25	40	65	8	6

外径 DC Dia.	食付長 (PL) Chamfer Length	刃長 (LH) Length of Flutes	首下長 (LPR) Protruding Length	全長 (OAL) Overall Length	シャンク径 (DCON) Shank Dia.	刃数 (N) Number of Flutes
9.0	0.6	25	40	65	8	6
9.01 ~ 9.05	0.6	25	40	65	8	6
9.1 ~ 9.5	0.6	25	40	65	8	6
9.6 ~ 9.9	0.6	25	40	65	8	6
9.97 ~ 9.99	0.6	25	40	65	8	6
10.0	0.6	25	40	65	8	6
10.01 ~ 10.05	0.6	25	40	65	8	6
10.1 ~ 10.5	0.6	30	40	70	8	6
10.6 ~ 10.9	0.6	30	40	70	8	6
10.97 ~ 10.99	0.8	30	40	70	10	6
11.0	0.8	30	40	70	10	6
11.01 ~ 11.05	0.8	30	40	70	10	6
11.1 ~ 11.5	0.8	30	40	70	10	6
11.6 ~ 11.9	0.8	30	40	70	10	6
11.97 ~ 11.99	0.8	30	40	70	10	6
12.0	0.8	30	40	70	10	6
12.01 ~ 12.05	0.8	30	40	70	10	6

### 技術資料 Technical Data

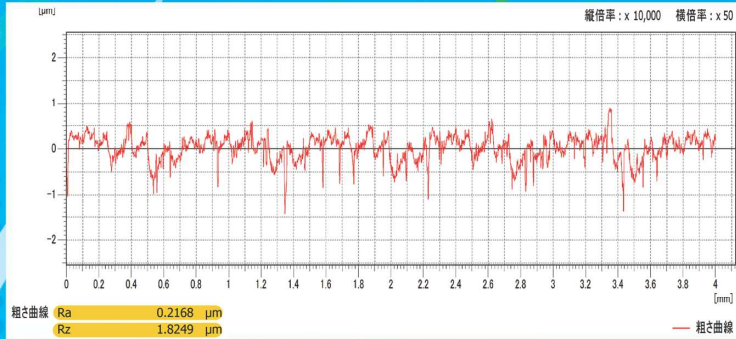

### ワーク/Work Material S45C

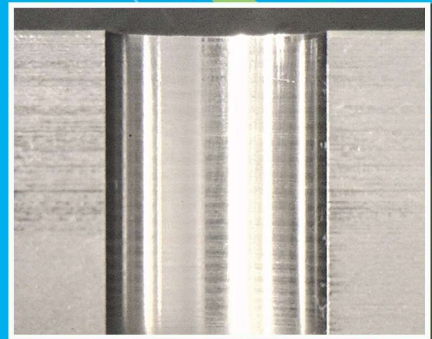

株式会社 栄工舎  
EIKOSHA CO., LTD.

本社・東京営業所 Head Office/Tokyo Sales Office  
〒144-0052 東京都大田区蒲田 3-16-12  
3-16-12 Kamata Ota Ward 144-0052 Tokyo  
TEL 03-3738-3970 FAX 03-3732-3665

大阪営業所 Osaka Sales Office  
〒532-0011 大阪市淀川区西中島 7-6-12  
新大阪駅前和光ビル 801号  
7-6-12 Nishinakajima Yodogawa Ward  
532-0011 Osaka  
TEL 06-6838-3936 FAX 06-6838-3937



ISO 9001:2015