

切削条件参考表 Cutting Condition Table

S-CSTPR ソリッドショートテーパーパーピンリーマ Solid Carbide Short Taper Pin Reamer

直径 Dia.	非鉄金属 Al,Cu		炭素鋼 FC,FCD,S50C		合金鋼 SCM,SKD,SUS304		調質鋼 HPM,NAK	
	切削速度 Cutting speed 12~18m/mm		切削速度 Cutting speed 8~12m/mm		切削速度 Cutting speed 6~9m/mm		切削速度 Cutting speed 4~8m/mm	
	回転数 spindle speed rpm	送り feed mm/min	回転数 spindle speed rpm	送り feed mm/min	回転数 spindle speed rpm	送り feed mm/min	回転数 spindle speed rpm	送り feed mm/min
1	3,820 ~ 5,730	46 ~ 69	2,546 ~ 3,820	31 ~ 46	1,910 ~ 2,865	23 ~ 34	1,273 ~ 2,546	15 ~ 31
2	1,910 ~ 2,865	27 ~ 41	1,273 ~ 1,910	18 ~ 27	955 ~ 1,432	14 ~ 20	637 ~ 1,273	9 ~ 18
3	1,273 ~ 1,910	21 ~ 32	849 ~ 1,273	14 ~ 21	637 ~ 955	11 ~ 16	424 ~ 849	7 ~ 14
4	955 ~ 1,432	18 ~ 27	637 ~ 955	12 ~ 18	477 ~ 716	9 ~ 13	318 ~ 637	6 ~ 12
5	764 ~ 1,146	16 ~ 24	509 ~ 764	11 ~ 16	382 ~ 573	8 ~ 12	255 ~ 509	5 ~ 11
6	637 ~ 955	15 ~ 22	424 ~ 637	10 ~ 15	318 ~ 477	7 ~ 11	212 ~ 424	5 ~ 10
7	546 ~ 819	14 ~ 21	364 ~ 546	9 ~ 14	273 ~ 409	7 ~ 10	182 ~ 364	5 ~ 9
8	477 ~ 716	13 ~ 20	318 ~ 477	9 ~ 13	239 ~ 358	7 ~ 10	159 ~ 318	4 ~ 9
10	382 ~ 573	12 ~ 18	255 ~ 382	8 ~ 12	191 ~ 286	6 ~ 9	127 ~ 255	4 ~ 8
12	318 ~ 477	12 ~ 18	212 ~ 318	8 ~ 12	159 ~ 239	6 ~ 9	106 ~ 212	4 ~ 8
13	294 ~ 441	11 ~ 17	196 ~ 294	8 ~ 11	147 ~ 220	6 ~ 9	98 ~ 196	4 ~ 8

S-TPR ショートテーパーパーピンリーマ Short Taper Pin Reamer

直径 Dia.	非鉄金属 Al,Cu		炭素鋼 FC,FCD,S50C		合金鋼 SCM,SKD,SUS304		調質鋼 HPM,NAK	
	切削速度 Cutting speed 10~15m/mm		切削速度 Cutting speed 7~10m/mm		切削速度 Cutting speed 5~8m/mm		切削速度 Cutting speed 4~7m/mm	
	回転数 spindle speed rpm	送り feed mm/min	回転数 spindle speed rpm	送り feed mm/min	回転数 spindle speed rpm	送り feed mm/min	回転数 spindle speed rpm	送り feed mm/min
1	3,183 ~ 4,775	38 ~ 57	2,228 ~ 3,183	27 ~ 38	1,592 ~ 2,546	19 ~ 31	1,273 ~ 2,228	15 ~ 27
2	1,592 ~ 2,387	23 ~ 34	1,114 ~ 1,592	16 ~ 23	796 ~ 1,273	11 ~ 18	637 ~ 1,114	9 ~ 16
3	1,061 ~ 1,592	18 ~ 26	743 ~ 1,061	12 ~ 18	531 ~ 849	9 ~ 14	424 ~ 743	7 ~ 12
4	796 ~ 1,194	15 ~ 22	557 ~ 796	10 ~ 15	398 ~ 637	7 ~ 12	318 ~ 557	6 ~ 10
5	637 ~ 955	13 ~ 20	446 ~ 637	9 ~ 13	318 ~ 509	7 ~ 11	255 ~ 446	5 ~ 9
6	531 ~ 796	12 ~ 19	371 ~ 531	9 ~ 12	265 ~ 424	6 ~ 10	212 ~ 371	5 ~ 9
7	455 ~ 682	12 ~ 17	318 ~ 455	8 ~ 12	227 ~ 364	6 ~ 9	182 ~ 318	5 ~ 8
8	398 ~ 597	11 ~ 17	279 ~ 398	8 ~ 11	199 ~ 318	6 ~ 9	159 ~ 279	4 ~ 8
9	354 ~ 531	10 ~ 16	248 ~ 354	7 ~ 11	177 ~ 283	5 ~ 8	141 ~ 248	4 ~ 7
10	318 ~ 477	10 ~ 15	223 ~ 318	7 ~ 10	159 ~ 255	5 ~ 8	127 ~ 223	4 ~ 7
11	289 ~ 434	9 ~ 15	203 ~ 289	6 ~ 9	145 ~ 231	5 ~ 7	116 ~ 203	4 ~ 6
12	265 ~ 398	8 ~ 14	186 ~ 265	6 ~ 9	133 ~ 212	5 ~ 7	106 ~ 186	4 ~ 6

S-TPD ソリッドショートテーパーパーピンドリル Short Taper Pin Drill

直径 Dia.	非鉄金属 Al,Cu		炭素鋼 FC,FCD,S50C		合金鋼 SCM,SKD,SUS304		調質鋼 HPM,NAK	
	切削速度 Cutting speed 15~25m/mm		切削速度 Cutting speed 12~18m/mm		切削速度 Cutting speed 10~14m/mm		切削速度 Cutting speed 8~12m/mm	
	回転数 spindle speed rpm	送り feed mm/min	回転数 spindle speed rpm	送り feed mm/min	回転数 spindle speed rpm	送り feed mm/min	回転数 spindle speed rpm	送り feed mm/min
2	2,094 ~ 3,490	109 ~ 272	1,675 ~ 2,234	44 ~ 87	1,396 ~ 1,955	27 ~ 63	1,117 ~ 1,675	12 ~ 35
2.5	1,701 ~ 2,835	99 ~ 247	1,361 ~ 1,815	40 ~ 79	1,134 ~ 1,588	25 ~ 58	907 ~ 1,361	11 ~ 32
3	1,415 ~ 2,359	82 ~ 205	1,132 ~ 1,510	33 ~ 65	944 ~ 1,321	20 ~ 48	755 ~ 1,132	9 ~ 26
4	1,072 ~ 1,787	67 ~ 168	858 ~ 1,144	27 ~ 54	715 ~ 1,001	17 ~ 39	572 ~ 858	7 ~ 22
5	863 ~ 1,438	57 ~ 143	690 ~ 920	23 ~ 46	575 ~ 805	14 ~ 33	460 ~ 690	6 ~ 18
6	723 ~ 1,205	50 ~ 124	578 ~ 771	20 ~ 40	482 ~ 675	12 ~ 29	385 ~ 578	5 ~ 16
7	617 ~ 1,028	41 ~ 103	494 ~ 658	16 ~ 33	411 ~ 576	10 ~ 24	329 ~ 494	4 ~ 13
8	537 ~ 895	35 ~ 86	430 ~ 573	14 ~ 28	358 ~ 501	9 ~ 20	287 ~ 430	4 ~ 11
9	476 ~ 794	30 ~ 75	381 ~ 508	12 ~ 24	317 ~ 444	7 ~ 17	254 ~ 381	3 ~ 10
10	433 ~ 722	30 ~ 74	346 ~ 462	12 ~ 24	289 ~ 404	7 ~ 17	231 ~ 346	3 ~ 9
11	395 ~ 658	28 ~ 69	316 ~ 421	11 ~ 22	263 ~ 368	7 ~ 16	211 ~ 316	3 ~ 9
12	363 ~ 605	26 ~ 65	290 ~ 387	10 ~ 21	242 ~ 339	7 ~ 15	194 ~ 290	3 ~ 8

S-CSTPR/S-TPR/S-TPD

ソリッドショートテーパーパーピンリーマ Solid Carbide Short Taper Pin Reamer



ショートテーパーパーピンリーマ Short Taper Pin Reamer



ショートテーパーパーピンドリル Short Taper Pin Drill



1/50 テーパーピン穴加工専用リーマと下加工用ドリル
Reamer for 1/50 taper pin holes and drill for pre-machining.
短いピンに対応したショートサイズ
Short size for short pins.



株式会社 栄工舎
EIKOSHA CO., LTD.

本社・東京営業所 Head Office/Tokyo Sales Office
〒144-0052 東京都大田区蒲田 3-16-12
3-16-12 Kamata Ota Ward 144-0052 Tokyo Japan
TEL 03-3738-3970 FAX 03-3732-3665

大阪営業所 Osaka Sales Office
〒532-0011 大阪市淀川区西中島 7-6-12
新大阪駅前和光ビル 801号
7-6-12 Nishinakajima Yodogawa Ward
532-0011 Osaka Japan
TEL 06-6838-3936 FAX 06-6838-3937



ISO 9001:2015



株式会社 栄工舎
EIKOSHA CO., LTD.

<https://www.eiko-sha.co.jp/>



EIKO TOOL



S-CSTPR ソリッドショートテーパーピンリーマ

Solid Carbide Short Taper Pin Reamer

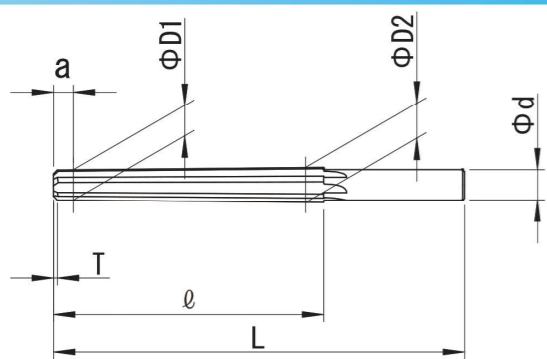

1/50テーパー 右刃ストレート 食付角度45° K10
1/50Taper Straight Flute Chamfer Angle45° K10

右直刃 食付 45° K10

公差(Tolerance) D1±0.05 d:h6

ΦD1≥4

小径 (φD1) First Dia.	食付長 (T) Chamfer Length	刃長 (ℓ) Length of Flutes	大径 (φD2) Dia at Large End	全長 (L) Overall Length	シャンク径 (φd) Shank Dia.	a	刃数 (N) Number of Flutes	センタ Center
1	-	14	1.18	32	2	5	4	60°凸
1.2	-	16	1.42	35	2	5	4	60°凸
1.5	-	19	1.78	40	2.5	5	4	60°凸
1.6	-	19	1.88	40	2.5	5	4	60°凸
1.8	-	24	2.18	46	3	5	4	60°凸
2	-	24	2.38	46	3	5	4	60°凸
2.5	-	27	2.94	49	3	5	4	60°凸
3	-	32	3.54	57	3	5	6	60°凸

小径 (φD1) First Dia.	食付長 (T) Chamfer Length	刃長 (ℓ) Length of Flutes	大径 (φD2) Dia at Large End	全長 (L) Overall Length	シャンク径 (φd) Shank Dia.	a	刃数 (N) Number of Flutes	センタ Center
4	0.5	38	4.66	65	4	5	6	60°凹
5	0.5	44	5.78	72	5	5	6	60°凹
6	1	50	6.9	81	6	5	6	60°凹
7	1	60	8.1	93	8	5	6	60°凹
8	1	71	9.32	108	8	5	6	60°凹
10	1	82	11.54	124	10	5	8	60°凹
12	1	97	13.8	144	12	7	8	60°凹
13	1	97	14.8	144	14	7	8	60°凹

S-TPR ショートテーパーピンリーマ

Short Taper Pin Reamer

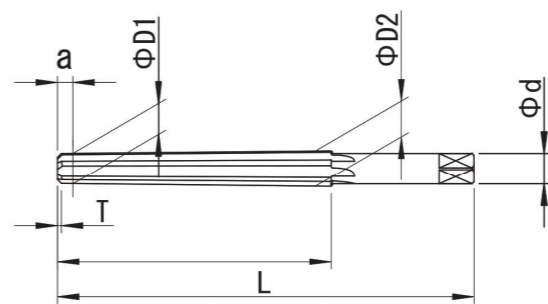

1/50テーパー 右刃ストレート 食付角度45° SKH51
1/50Taper Straight Flute Chamfer Angle45° HSS

右直刃 食付 45° HSS

公差(Tolerance) D1±0.05 d:±0.2

ΦD1≥3.5

小径 (φD1) First Dia.	食付長 (T) Chamfer Length	刃長 (ℓ) Length of Flutes	大径 (φD2) Dia at Large End	全長 (L) Overall Length	シャンク径 (φd) Shank Dia.	a	刃数 (N) Number of Flutes	センタ Center
0.8	-	12	0.94	30	2	5	4	60°凸
0.9	-	14	1.08	32	2	5	4	60°凸
1	-	14	1.18	32	2	5	4	60°凸
1.1	-	16	1.32	35	2	5	4	60°凸
1.2	-	16	1.42	35	2	5	4	60°凸
1.3	-	19	1.58	40	2.5	5	4	60°凸
1.4	-	19	1.68	40	2.5	5	4	60°凸
1.5	-	19	1.78	40	2.5	5	4	60°凸
1.6	-	19	1.88	40	2.5	5	4	60°凸
1.7	-	24	2.08	46	3	5	4	60°凸
1.8	-	24	2.18	46	3	5	4	60°凸
1.9	-	24	2.28	46	3	5	4	60°凸
2	-	24	2.38	46	3	5	4	60°凸
2.1	-	27	2.54	49	3	5	4	60°凸
2.2	-	27	2.64	49	3	5	4	60°凸
2.3	-	27	2.74	49	3	5	4	60°凸
2.4	-	27	2.84	49	3	5	4	60°凸
2.5	-	27	2.94	49	3	5	4	60°凸
2.6	-	32	3.14	57	3	5	4	60°凸
2.7	-	32	3.24	57	3	5	4	60°凸

小径 (φD1) First Dia.	食付長 (T) Chamfer Length	刃長 (ℓ) Length of Flutes	大径 (φD2) Dia at Large End	全長 (L) Overall Length	シャンク径 (φd) Shank Dia.	a	刃数 (N) Number of Flutes	センタ Center
2.8	-	32	3.34	57	3	5	4	60°凸
2.9	-	32	3.44	57	3	5	4	60°凸
3	-	32	3.54	57	3	5	6	60°凹
3.5	0.5	38	4.16	65	4	5	6	60°凹
4	0.5	38	4.66	65	4	5	6	60°凹
4.5	0.5	44	5.28	72	5	5	6	60°凹
5	0.5	44	5.78	72	5	5	6	60°凹
5.5	0.5	50	6.4	81	6	5	6	60°凹
6	1	50	6.9	81	6	5	6	60°凹
6.5	1	60	7.6	93	6	5	6	60°凹
7	1	60	8.1	93	8	5	6	60°凹
7.5	1	71	8.82	108	8	5	6	60°凹
8	1	71	9.32	108	8	5	6	60°凹
8.5	1	82	10.04	124	10	5	8	60°凹
9	1	82	10.54	124	10	5	8	60°凹
9.5	1	82	11.04	124	10	5	8	60°凹
10	1	82	11.54	124	10	5	8	60°凹
11	1	97	12.8	144	12	7	8	60°凹
12	1	97	13.8	144	12	7	8	60°凹

S-TPD ショートテーパーピンドリル

Short Taper Pin Drill

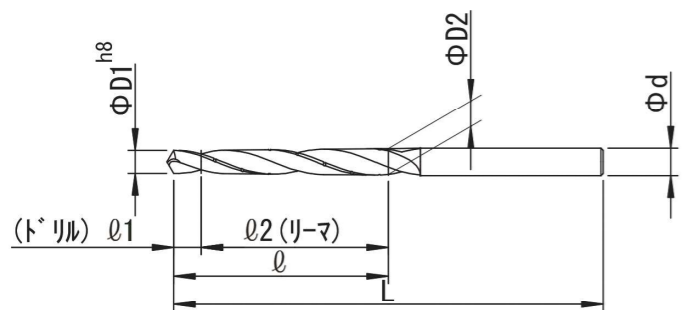

1/50テーパー 右刃右ネジレ 刃数2 SKH56
1/50Taper Helix Angle-Right 2Flutes HSS-Co.

右ネジレ 25° HSS Co 刃数 2

公差(Tolerance) D1:h8 d:h7

呼び寸法 Size	小径 (φD1) First Dia.	刃長 (ℓ) Length of Flutes	大径 (φD2) Dia at Large End	ドリル長 (ℓ1) Length of Drill	リーマ長 (ℓ2) Length of Reamer	全長 (L) Overall Length	シャンク径 (φd) Shank Dia.
2	1.98	24	2.42	2	22	44	2.5
2.5	2.48	28	2.96	4	24	51	3
3	2.98	33	3.56	4	29	71	4
4	3.98	39	4.68	4	35	80	5
5	4.98	47	5.8	6	41	94	6
6	5.97	53	6.91	6	47	103	7

呼び寸法 Size	小径 (φD1) First Dia.	刃長 (ℓ) Length of Flutes	大径 (φD2) Dia at Large End	ドリル長 (ℓ1) Length of Drill	リーマ長 (ℓ2) Length of Reamer	全長 (L) Overall Length	シャンク径 (φd) Shank Dia.
7	6.97	63	8.11	6	57	118	8
8	7.97	78	9.33	10	68	137	9
9	8.96	89	10.54	10	79	151	10
10	9.96	89	11.54	10	79	151	11
11	10.96	94	12.64	10	84	161	12
12	11.96	104	13.74	15	89	172	13